

# Model VCD 1000

Variable Constant Differential Flow Controller

## Customer Value Proposition:

The Porter model VCD 1000 flow controller is precision-engineered to control low gas flows at constant mass flow rates regardless of changes in downstream pressure. The VCD 1000 maintains a preset pressure differential across a laminar flow element. Turning the fine-pitched adjusting stem varies the force on an internal diaphragm, which alters the differential pressure across the laminar flow element, thereby changing the flow rate. This design yields extremely linear flow output in relation to stem rotation and virtually eliminates the sawtoothing associated with valve-based controllers. The laminar flow elements are available in full scale flow rates from 5 sccm up to 1500 sccm (He @ 70 °F and 50 PSIG).



## Contact Information: Product Features:

Parker Hannifin Corporation  
**Porter Instrument Division**  
245 Township Line Road  
Hatfield, PA 19440

phone 215 723 4000  
fax 215 723 2199  
industrial@parker.com

[www.parker.com/porter](http://www.parker.com/porter)

- Delrin® adjusting stem with 56 pitch threads
- Turns vs. flow relationship is linear
- Bubble-tight shut-off
- Full scale flow rates from 5 SCCM up to 1500 SCCM (He @ 70 °F and 50 PSIG)
- Replaceable inlet filter included
- Standard panel mount configuration



ENGINEERING YOUR SUCCESS.

## Specifications

Capacities- See chart on next page

Ratings- Maximum operating pressure: 250 psig; maximum operating temperature; 160°F; pressure drop required: 15 psi minimum

Performance- Control accuracy: 0.3% of instantaneous flow rate. Adjustability: 0-100% of flow over 14 turns

Connections- 1/8" compression fitting (brass) with aluminum body; 1/8" compression fitting (stainless steel) with SS body

Dimensions- Refer to diagram

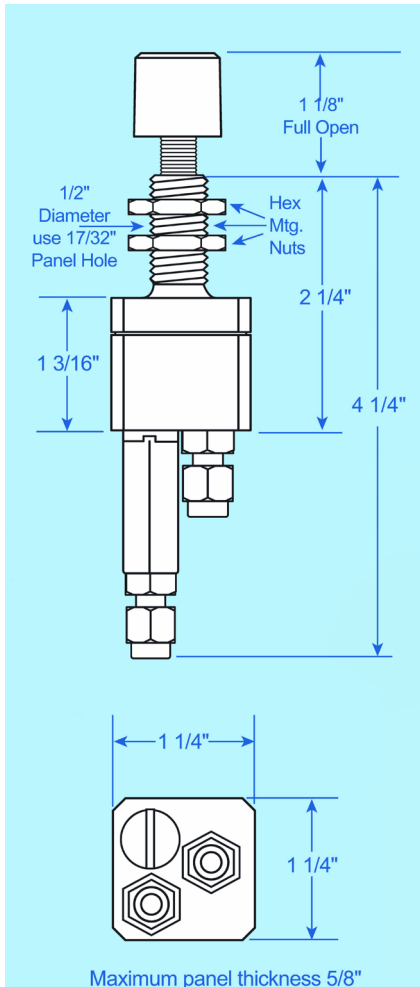

Specifications subject to change without notice. For current information please call 215-723-4000 or visit us at [www.parker.com/porter](http://www.parker.com/porter)



## Materials of Construction

Controller Body- Aluminum or stainless steel

Controller Diaphragm- Fairprene® BN-5029 or stainless steel

Orifice- Brass with aluminum body; 316 stainless steel with stainless steel body

O-Rings- Buna N or Viton

Filter- Aluminum with aluminum body; stainless steel with stainless steel body

### Ordering Information

#### Model Number and Description

#### VCD Flow

Controller Example: VCD A B F B

#### Basic Model

#### Body Material

A - Aluminum  
S - Stainless Steel

#### O-Ring Material

B - Buna N  
V - Viton

#### Diaphragm Material

F - Fairprene BN-5029  
S - 316 Stainless Steel

#### Flow Element Size Number

5, 8, 10, 15, 25, 35, 45, 60, 95, 110  
144, 180, 400, 465, 750, 1000, 1500

#### To order, specify:

- Model Number
- Flow Rate
- Gas Type
- Operating Pressure (inlet)
- Operating Temperature
- Body Material
- O-Ring Material
- Diaphragm Material

Delrin® - DuPont de Nemours & Co.

Fairprene® - Fairprene, Inc.

ENGINEERING YOUR SUCCESS.

## VCD 1000 Capacities

Maximum Flow Range	Flow Element Size Number	Color Code on Flow Element
5 cc/min	5	Gold Anodize w/ Red Dot
8 cc/min	8	Blue Anodize w/ Red Dot
10 cc/min	10	Blue Anodize
15 cc/min	15	Silver Anodize w/ Blue Dot
25 cc/min	25	Red Anodize w/ Silver Dot
35 cc/min	35	Black Anodize w/ White Dot
45 cc/min	45	Blue Anodize w/ Green Dot
60 cc/min	60	Red Anodize
95 cc/min	95	Gold Anodize

Maximum Flow Range	Flow Element Size Number	Color Code on Flow Element
110 cc/min	110	Green Anodize
144 cc/min	144	Silver Anodize w/ Red Dot
180 cc/min	180	Silver Anodize
535 cc/min	400	Black Anodize
465 cc/min	465	Black Anodize w/ Silver Dot
750 cc/min	750	Silver Anodize w/ Green Dot
1060 cc/min	1000	Black Anodize w/ Red Dot
1600	1500	Black Anodize w/ Green Dot

\* Flow ranges stated are based on helium gas at 50 psig supply pressure

\*\* Color-coded flow element packages appear on aluminum units only. Stainless steel flow controllers have flow element size etched on the flow element holder.

## Certificate of Warranty

THIS WARRANTY IS GIVEN IN PLACE OF ALL OTHER WARRANTIES, EXPRESS OR IMPLIED, OF MERCHANTABILITY, FITNESS FOR A PARTICULAR PURPOSE, OR OTHERWISE. NO PROMISE OR STATEMENT MADE BY ANY REPRESENTATIVE OR AUTHORIZED DEALER OF PORTER INSTRUMENT CO., INC. SHALL CONSTITUTE A WARRANTY BY PORTER INSTRUMENT CO., INC. PORTER INSTRUMENT CO., INC. ASSUMES NO LIABILITY FOR USE OF THIS EQUIPMENT.

Porter Instrument Co., Inc. warrants this equipment to be free from defects in workmanship and materials, when used in accordance with applicable specifications and with appropriate maintenance, for one (1) year from date of delivery to the customer, unless otherwise specified in writing.

Equipment which malfunctions may be returned, shipment prepaid, to Porter Instrument Co., Inc. for test and evaluation. Equipment determined to be defective and in warranty will be repaired or replaced at no charge to the customer.

Equipment out of warranty will be evaluated, and if the equipment does not meet original specifications and calibration, the customer will be notified of the costs before proceeding with repair or

replacement. Repaired equipment will be warranted ninety (90) days from date of delivery to the customer or for the balance of the original warranty, whichever is longer.

Failures due to shipping damage, accident, misuse, improper mechanical or electrical installation or operation, or internal clogging or corrosion due to contaminated fluids or inadequate system purging are excluded from warranty coverage.

Porter Instrument Co., Inc.'s obligation for breach of this warranty, or for negligence or otherwise, shall be strictly and exclusively limited to the repair or replacement of the equipment. This warranty shall be void as to any equipment on which the serial number, if applicable, has been altered, defaced, or removed. Porter Instrument Co., Inc. shall under no circumstances be liable for incidental or consequential damages.

No other promise or statement about the equipment by any representative or authorized dealer of Porter Instrument Co., Inc. shall constitute a warranty by Porter Instrument Company, Inc. or give rise to any liability or obligation of Porter Instrument Co., Inc. Specifications and dimensions subject to change