

# P430 Series

## Glass Tube Flow Meters



Parker P Series glass tube flowmeters deliver unsurpassed performance and value in a wide variety of gas and liquid applications. P430 Series flow meters feature borosilicate glass tubes with stainless steel frames and horizontal connections and are available with 65mm and 150mm scale sizes. Available Fiber-Optic or Inductive Ring Sensor Alarms, as well as integrated metering valves provide the needed versatility for many industrial process and sample handling applications.



### Contact Information:

Parker Hannifin Corporation  
**Porter Instrument Division**  
245 Township Line Road  
Hatfield, PA 19440

phone 215 723 4000  
fax 215 723 2199  
Industrial@parker.com

www.parker.com

### Product Features and Options:

- Borosilicate glass metering tube.
- Max temperature:  
250°F (121°C) for gases  
200°F (93°C) for liquids
- Max Pressure: 200 PSIG  
(see specifications)
- Optional inductive ring and fiber optic alarm sensors available.
- Certified calibrations conforming to ISA RP 16.6 available.
- Direct reading detachable scales available in any volumetric unit.



ENGINEERING YOUR SUCCESS.

# Specifications

## Materials

<b>Metering Tube</b>	Borosilicate Glass
<b>Internal Components</b>	316L Stainless Steel, Black Glass, Sapphire, Carboly, Tantalum
<b>Inlet/Outlet Fittings</b>	1/8" and 1/4" FNPT, Horizontal Control Valve Optional
<b>Fitting Material</b>	316L Stainless Steel
<b>Elastomers</b>	Standard: Viton® Optional: Buna, EPR, and Kalrez®

## Options

<b>Alarm</b>	Fiber-Optic or Inductive Ring Sensor (see details)
<b>Certified Calibrations</b>	Conform to ISA RP 16.6
<b>Scales</b>	Can be produced in any volumetric unit

Viton® and Kalrez® are registered trademarks of DuPont Performance Elastomers L.L.C.

## Performance

<b>Capacities</b>	Water .72 to 1,800 cc/mn Air 66 to 70,000 cc/mn
<b>Scale</b>	65mm, 150mm Direct reading, detachable
<b>Accuracy</b>	65mm ±6% of Full Scale Flow 150mm ±4% of Full Scale Flow
<b>Turndown</b>	10:1 to 12.5:1, unless otherwise indicated
<b>Repeatability</b>	1%
<b>Maximum Temperature</b>	Gases 250°F (121°C) Liquids 200°F (93°C)
<b>Maximum Pressures</b>	316L SS Fittings 200 psig PVC Fittings 130 psig PVDF Fittings 150 psig
<b>Ambient Temperature</b>	33°F to 125°F (1°C to 52°C)

## Alarm Options:

### Inductive Ring Sensor

Inductive ring sensors are designed to be used with a remote intrinsic safety barrier/switch isolator. These sensors are able to detect the metal float by producing an electromagnetic field within the ring. Ring sensors are available in either proximity or latching format for the P430 Series.

### Sensor Specifications

<b>Power Supply</b>	5-25 VDC (from Switch Isolator)
<b>Maximum Current</b>	Target Present: 1 mA Target Absent: 15 mA
<b>Temperature Limits</b>	-14°F to +158°F (-26°C to +70°C)
<b>Output</b>	NAMUR
<b>Repeatability</b>	0.01mm
<b>Switching Frequency</b>	2 kHz (.125"), 1.5 kHz (.25")
<b>Sensor Approvals</b>	UL Listed: General Purpose FM Approved: Intrinsically Safe* CSA Certified: Intrinsically Safe* Genelec: Intrinsically Safe*

\*Additional cost, call for pricing

### Float/Sensor Compatibility

Type	Tube Sizes	Float Material
<b>Proximity</b>	.125" .25"	SS, CB
<b>Latching</b>	.125" .25"	SS, CB

### Fiber Optic Sensor

The fiber optic sensor is housed in a junction box attached to the side of a P430 Series flowmeter. The sensor uses a pair of fiber optic cables, an emitter and receiver to transmit the light across the metering tube and back to the sensor. If the light beam is blocked by the float, the sensor output will change. The sensor provides a transistor output that switches the common or negative voltage (NPN) or positive voltage (PNP) to the load. The fiber optic sensor is compatible with all P430 Series float types.

### Sensor Specifications

<b>Supply Voltage</b>	10-30 VDC
<b>Current Consumption</b>	25 mA
<b>Temperature Limits</b>	-14°F to +212°F (-26C to +100°C)
<b>Offstate Leakage Current</b>	1 microamp at 30 VDC
<b>Output Saturation Voltage</b>	1 V at 10 mA DC < 1.5 V at 150 mA DC

**Note:** Sapphire floats are not compatible with Fiber Optic Sensor

## Flow Ranges

65mm Scale Flow Ranges							
Tube Number	Float Material	Air (STP)			Water (70°F)		
		CC/MIN	SCFH	SLPH	CC/MIN	GPH	LPH
A1	Glass	66	.14	4.0	0.72	.011	.042
	Sapphire	105	.22	6.2	1.3	.021	.078
	Stainless Steel	200	.42	12.0	3.3	.052	.190
	Carboloy	340	.70	20.0	7.0	.110	.420
	Tantalum	350	.74	21.0	7.8	.125	.460
A2	Glass	76	.16	4.6	1.15	.018	.068
	Sapphire	120	.25	7.2	2.10	.032	.125
	Stainless Steel	230	.50	14.0	4.20	.068	.260
	Carboloy	400	.85	24.0	9.0	.145	.560
	Tantalum	440	.90	26.0	10.0	.165	.620
A3	Glass	525	1.1	31	9.0	.140	.540
	Sapphire	700	1.5	42	15.5	.240	.950
	Stainless Steel	1130	2.4	68	29.0	.460	1.7
	Carboloy	1600	3.4	95	46.0	.720	2.8
	Tantalum	1700	3.6	100	50.0	.780	3.0
A4	Glass	2000	4.2	120	44	.700	2.6
	Sapphire	2600	5.4	150	68	1.05	4.0
	Stainless Steel	3800	8.2	230	110	1.70	6.6
	Carboloy	5600	12.0	340	170	2.70	10.5
	Tantalum	6000	13.0	360	180	2.90	11.0
A5	Glass	6800	14.5	400	160	2.60	9.5
	Sapphire	9200	19.5	540	240	3.80	14.5
	Stainless Steel	13,000	28.0	800	400	6.40	24.0
	Carboloy	19,000	40.0	1100	600	9.50	36.0
	Tantalum	20,000	42.0	1200	640	10.00	38.0
A6	Glass	19,000	40.0	1150	520	8.25	31.0
	Sapphire	25,000	52.0	1500	740	11.50	44.0
	Stainless Steel	42,500	90.0	2550	1200	19.00	72.0
	Carboloy	60,000	125.0	3600	1700	27.00	105.0
	Tantalum	70,000	145.0	4200	1800	29.00	110.0

150mm Scale Flow Ranges							
Tube Number	Float Material	Air (STP)			Water (70°F)		
		CC/MIN	SCFH	SLPH	CC/MIN	GPH	LPH
B1	Carboloy	280	.580	16.5	5.00	.0780	.300
	Tantalum	300	.620	17.5	5.20	.0840	.320
B2	Glass	106	.225	6.4	1.24	.0195	.074
	Sapphire	165	.35	10	2.35	.0380	.145
	Stainless Steel	320	.68	19	5.60	.0900	.340
	Carboloy	540	1.14	32	12.4	.1950	.740
B3	Tantalum	580	1.24	35	13.5	.2100	.820
	Glass	350	.74	21	4.7	.074	.28
	Sapphire	500	1.06	30	10.0	.160	.60
	Stainless Steel	820	1.75	50	20.5	.330	1.25
	Carboloy	1,250	2.6	76	34.0	.540	2.05
B4	Tantalum	1,350	2.9	80	36.0	.560	2.15
	Glass	850	1.8	50	16.5	.26	1.0
	Sapphire	1,100	2.3	66	27.0	.42	1.6
	Stainless Steel	1,600	3.4	100	46.0	.72	2.7
	Carboloy	2,300	4.9	140	72.0	1.15	4.4
	Tantalum	2,450	5.2	155	80.0	1.25	4.8
B5	Glass	2,150	4.6	130	52	.84	3.1
	Sapphire	2,800	6.0	170	78	1.24	4.7
	Stainless Steel	4,400	9.2	260	130	2.05	7.8
	Carboloy	6,200	13.5	380	205	3.20	12.5
	Tantalum	6,750	14.0	400	210	3.30	12.5
B6	Glass	3,800	8.2	230	86	1.35	5.2
	Sapphire	5,000	10.6	300	130	2.05	7.8
	Stainless Steel	7,500	16.0	450	220	3.40	13.0
	Carboloy	10,600	22.5	640	330	5.20	20.0
	Tantalum	11,500	24.0	680	360	5.60	21.5
	Glass	9,000	19.0	540	215	3.40	13.0
B7	Sapphire	11,400	24.5	700	320	5.00	19.0
	Stainless Steel	17,000	36.0	1,000	520	8.20	31.0
	Carboloy	24,000	50.0	1,450	760	12.2	46.0
	Tantalum	25,000	54.0	1,500	820	13.0	49.0
	Glass	20,500	43.0	1,220	470	7.5	28.0
B8	Sapphire	26,000	56.0	1,550	700	11.0	42.0
	Stainless Steel	38,000	82.0	2,300	1120	18.0	68.0
	Carboloy	54,000	116.0	3,300	1650	26.0	100.0
	Tantalum	60,000	125.0	3,500	1750	28.0	106.0

# Ordering Information

Use the following guide to determine the specific product number you require.

The following example describes a P430 series flow meter, tube number A1, with a glass float, 1/4" FNPT fitting of 316L stainless steel, a Buna O-ring, with a scale in millimeters and 316L stainless steel inlet valve. It does not have an optional alarm.

**Example:** P430A1123110

P430	A1	1	2	3	1	1	0
Meter Series	Tube Number	Float Material	Fitting Material	O-Ring Material	Scale	Valve Option	Optional Alarm Switch
P430	See Flow Ranges Table	1 Glass 2 Sapphire 3 316 Stainless Steel 4 Carboly 5 Tantalum	1 316L Stainless Steel – 1/8" FNPT 2 316L Stainless Steel – 1/4" FNPT 3 PVC – 1/4" FNPT 4 PVC – 1/8" FNPT 5 PVDF – 1/4" FNPT 6 PVDF – 1/8" FNPT 7 Hastelloy® C – 1/4" FNPT 8 Hastelloy® C – 1/8" FNPT	1 Ethylene Propylene Rubber 2 Buna 3 Viton® 4 Kalrez® with No Valve 5 Kalrez® with Valve	1 Millimeter 2 GPH Water @ 70°F (21°C) 3 LPH Water @ 70°F (21°C) 4 cc/min Water @ STP 5 SCFH Air @ STP 6 SLPH Air @ STP 7 scc/min Air @ STP 8 Non-Standard	1 Inlet 316L Stainless Steel 2 Outlet 316L Stainless Steel 3 No Valve 4 Inlet PVC 5 Outlet PVC 6 Inlet PVDF 7 Outlet PVDF 8 Inlet Hastelloy® C 9 Outlet Hastelloy® C	0 No Alarm 1 Fiber Optic NPN (Proximity) 2 Fiber Optic PNP (Proximity) 3 Inductive Ring Sensor (Proximity) 4 Inductive Ring Sensor (Latching)

Hastelloy® is a registered trademark of Haynes International, Inc.  
Viton® and Kalrez® are registered trademarks of DuPont Performance Elastomers L.L.C.

# Dimensions

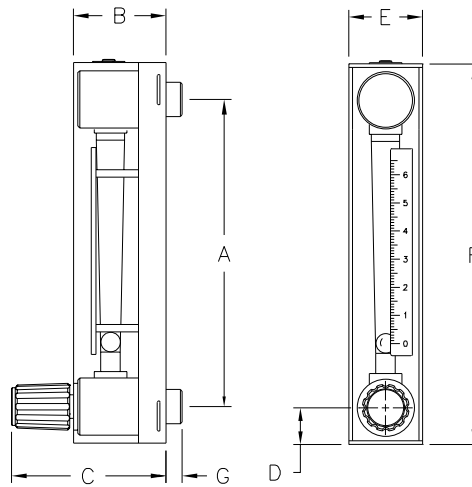

## Dimensions (inches)

	Scale Length	
	65mm	150mm
A*	4.53	8.826
B	1.56	1.56
C	2.90	2.90
D	0.73	0.73
E	1.50	1.50
F	6.05	10.25
G	0.50	.05

\*The FNPT fittings have a 3/4 – 16 O.D. thread with mounting nuts installed.

### ⚠ WARNING – USER RESPONSIBILITY

**FAILURE OR IMPROPER SELECTION OR IMPROPER USE OF THE PRODUCTS DESCRIBED HEREIN OR RELATED ITEMS CAN CAUSE DEATH, PERSONAL INJURY AND PROPERTY DAMAGE.**

This document and other information from Parker-Hannifin Corporation, its subsidiaries and authorized distributors provide product or system options for further investigation by users having technical expertise.

The user, through its own analysis and testing, is solely responsible for making the final selection of the system and components and assuring that all performance, endurance, maintenance, safety and warning requirements of the application are met. The user must analyze all aspects of the application, follow applicable industry standards, and follow the information concerning the product in the current product catalog and in any other materials provided from Parker or its subsidiaries or authorized distributors.

To the extent that Parker or its subsidiaries or authorized distributors provide component or system options based upon data or specifications provided by the user, the user is responsible for determining that such data and specifications are suitable and sufficient for all applications and reasonably foreseeable uses of the components or systems.

### Offer of Sale

The items described in this document are hereby offered for sale by Parker-Hannifin Corporation, its subsidiaries or its authorized distributors. This offer and its acceptance are governed by the provisions stated in the detailed "Offer of Sale" elsewhere in this document or available at [www.parker.com/safety](http://www.parker.com/safety).