

P100 Series

Low-Flow, High-Pressure Metal Tube Flow Meters



Parker P Series metal tube variable area flowmeters (armored rotameters) feature a robust design particularly suited for severe duty applications where safety is a concern. The P100 Series, with welded stainless steel construction and a maximum pressure rating of 4000 PSIG (1500 PSIG with Valve) is ideal for low flow high pressure applications. Hastelloy® construction is available for corrosive media applications.



Contact Information: Product Features and Options:

Parker Hannifin Corporation
Porter Instrument Division
245 Township Line Road
Hatfield, PA 19440

phone 215 723 4000
fax 215 723 2199
Industrial@parker.com

www.parker.com

- 316L or Hastelloy® C-276 internal parts.
- Max temperatures range from 275°F to 400°F. (See specifications.)
- Optional Inductive Slot Sensor Alarm.
- Scales can be produced in any volumetric unit.
- Certified calibrations conforming to ISA RP 16.6 available.
- 304 stainless steel rear mounting bracket is available.
- 4000 PSIG Maximum Pressure. (See specifications.)



ENGINEERING YOUR SUCCESS.

Specifications

Materials

Metering Tube	316L Stainless Steel Hastelloy® C-276
Internal Components	316L Stainless Steel Hastelloy® C-276
Inlet/Outlet Fittings	1/4" FNPT, Horizontal Control valve optional
Fitting Material	316L Stainless Steel Hastelloy® C-276
Connection Type	1/4" FNPT
Elastomers (valve meters only)	Standard Viton® Optional Buna, EPR, and Kalrez®
Case and Side Cover	Die Cast Aluminum

Options

Alarm	Single, Inductive Slot Sensor
Certified Calibrations	Conform to ISA RP 16.6
Scales	Can be produced in any volumetric unit
Rear Mounting Bracket	304 Stainless Steel

Performance

Capacities	Water	.16 to 25 GPH .6 to 95 LPH
	Air	1 to 120 SCFH 28.3 to 3400 SLPH
Scale	60 mm (2") Direct reading	
Accuracy	±5% of Full Scale Flow	
Turndown	10:1 to 12.5:1, unless otherwise indicated	
Repeatability	1%	
Maximum Temperatures	O-ring Mtl.	Max. Temp
	EPR	300°F (149°C)
	Buna	275°F (135°C)
	Viton®	350°F (177°C)
	Kalrez®	400°F (204°C)
No O-ring	400°F (204°C)	
Maximum Pressures	Valve models	1,500 psig
	Non-valve models	4,000 psig
Ambient Temperature	33°F to 125°F (1°C to 52°C)	

Alarm Options



The available alarm mechanism in this flow meter is a two-wired, DC, low current inductive slot sensor. It is designed to be used with a switch isolator/barrier.

Note: Parker can supply switch isolator/barriers upon request. User power supply voltage must be provided.

Dimensions (Inches)

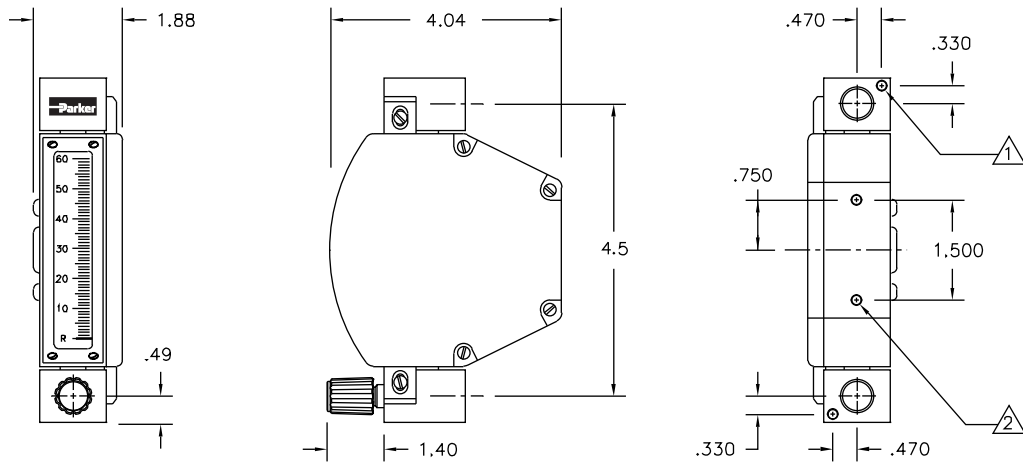

▲ 10 - 32 Threaded panel mounting holes - 2 places

▲ 2 10 - 32 Threaded hole for installing the optional back mounting bracket - 2 places

Flow Capacities

Order Number	Full Scale Flow Water - GPH	Full Scale Flow Water - LPH	Order Number	Full Scale Flow Air - SCFH	Full Scale Flow Air - SLPH
00W	0.16	0.6	00A	1.0	28.3
02W	0.6	2.4	01A	2.5	70.0
04W	1.2	4.5	03A	5.5	155.0
06W	2.8	10.5	05A	13.0	360.0
08W	5.5	20.0	07A	24.0	680.0
10W	12.0	45.0	09A	55.0	1,550.0
12W	25.0	95.0	11A	120.0	3,400.0

Ordering Information

Use the following guide to determine the specific product number you require.

The following example describes a P100 flowmeter with 316L stainless steel construction, EPR O-rings, an SCFH air scale, 316L stainless valve on outlet, no alarm and a flow capacity of 5.5 SCFH air.

Example: P1001142003A

Meter Series	Material of Construction	O-Ring Material	Scale Type	Valve Option	Optional Alarm	Order Number
P100	1 316L Stainless Steel 2 Hastelloy® C-276* 3 Monel*	0 No O-ring** 1 Ethylene Propylene Rubber 2 Buna 3 Viton® 4 Kalrez®	1 Millimeter 2 GPH - Water 3 LPH - Water 4 SCFH - Air - STP 5 SLPH - Air - STP 6 Non-Standard	1 Inlet 316L Stainless Steel 2 Outlet 316L Stainless Steel 3 No Valve 4 Inlet Hastelloy® C-276 5 Outlet Hastelloy® C-276	0 No Alarm A With Alarm	See Flow Capacities Table Above

* Consult factory on Hastelloy® and Monel construction for "00", "01" and "02" tube sizes.

** The "No O-ring" option is for non-valve meters only.

Hastelloy® is a registered trademark of Haynes International, Inc.

Viton® and Kalrez® are registered trademarks of DuPont Performance Elastomers L.L.C.

⚠ WARNING – USER RESPONSIBILITY

FAILURE OR IMPROPER SELECTION OR IMPROPER USE OF THE PRODUCTS DESCRIBED HEREIN OR RELATED ITEMS CAN CAUSE DEATH, PERSONAL INJURY AND PROPERTY DAMAGE.

This document and other information from Parker-Hannifin Corporation, its subsidiaries and authorized distributors provide product or system options for further investigation by users having technical expertise.

The user, through its own analysis and testing, is solely responsible for making the final selection of the system and components and assuring that all performance, endurance, maintenance, safety and warning requirements of the application are met. The user must analyze all aspects of the application, follow applicable industry standards, and follow the information concerning the product in the current product catalog and in any other materials provided from Parker or its subsidiaries or authorized distributors.

To the extent that Parker or its subsidiaries or authorized distributors provide component or system options based upon data or specifications provided by the user, the user is responsible for determining that such data and specifications are suitable and sufficient for all applications and reasonably foreseeable uses of the components or systems.

Offer of Sale

The items described in this document are hereby offered for sale by Parker-Hannifin Corporation, its subsidiaries or its authorized distributors. This offer and its acceptance are governed by the provisions stated in the detailed "Offer of Sale" elsewhere in this document or available at www.parker.com/safety.