

# Models 415 & 425

## Electronic Pressure Regulators

### Customer Value Proposition:

Porter models 415 and 425 electronic pressure regulators combine the proven Porter EPC proportional control valve with an integrally-mounted pressure sensor and the necessary electronics for self-contained closed-loop pressure control. Models 415 and 425 permit regulation of forward and back pressures respectively. The controlled pressure is established by a user-applied 0-5 Vdc setpoint voltage.

The exclusive absolute zero (ABZ) feature allows the pressure signal to be essentially clamped at zero for signals less than 1.5% full scale, which in turn forces the control valve closed. ABZ minimizes the zero drift effects due to temperature variation and guarantees the control valve will not open for setpoint values less than 1.5% full scale. When pressure is adjusted to greater than 1.5% full scale, the pressure signal is enabled and calibrated accuracy is achieved. The ABZ feature may be disabled by means of a control input at the electrical connector.



### Contact Information:

Parker Hannifin Corporation  
**Porter Instrument Division**  
245 Township Line Road  
Hatfield, PA 19440

phone 215 723 4000  
fax 215 723 2199  
industrial@parker.com

[www.parker.com/porter](http://www.parker.com/porter)



**ENGINEERING YOUR SUCCESS.**

# Specifications

**Performance:** performance specifications at 20 °C, 100 PSIG inlet pressure and +15 Vdc power supply voltage unless otherwise noted

**Gases Accommodated**.....any clean, dry gas compatible with materials of construction

**Maximum Inlet Pressure:**

Pressure Range	Maximum Inlet Pressure	Pressure Range	Maximum Inlet Pressure
0-5 PSIG	15 PSIG	0-30 PSIG	90 PSIG
0-10 PSIG	45 PSIG	0-50 PSIG	150 PSIG
0-15 PSIG	45 PSIG	0-100 PSIG	200 PSIG

**Pressure Regulation Accuracy:** ±1.5% F.S.  
**Pressure Regulation Linearity:** ±1% F.S.  
**Repeatability:** ±0.25% F.S.  
**Temperature Coefficient:** ±0.1% F.S./ °C maximum  
**Pressure Signal Zero Shift:**

ABZ ENABLED	ABZ DISABLED
<0.1% F.S. over 0-50°C range	<1% F.S. over 0-50°C range

**Valve Inboard Leak Rate:** 0.2 SCCM He @ 90 PSIG

## Electrical

**Pressure Signal Output:** 0-5 Vdc for 0 full scale pressure range (pressure signal output forced to 0 Vdc whenever less than 1.5% F.S. [75 mV] and ABZ is enabled)

**Setpoint Input-** 0-5 Vdc for 0 full scale pressure range

**Power Supply Voltage:** +12 to +24 Vdc (±10%)

**Maximum Operating Power @ +16.5 Vdc:** 2.25 watts (150 mA max. from +15 Vdc supply)

**Absolute Zero (ABZ) Input:**  
 Enable ABZ = No Connection  
 Disable ABZ = OV (threshold <3.0 Vdc)

## Mechanical

**Dimensions:** Refer to Dimensional Data section

**Mounting Orientation:** Attitude Sensitive

**Electrical Connector:** 8-contact (mating connector - AMP P/N 640441-8)

**Process Connections:** 1/16", 1/8" or 1/4" compression fittings



**ENGINEERING YOUR SUCCESS.**

## Materials of Construction

Body: Aluminum

Pressure Sensor Assembly: Pyrex®, ceramic, silicon, epoxy, RTV and stainless steel

Orifice: Brass

Valve Components (wetted): Aluminum, brass, 302 stainless steel, 305 stainless steel, 316 stainless steel, 430 stainless steel and Sandvik® 1802

Elastomers (O-rings and valve seat): Buna N, EPDM, Neoprene or Viton®

Process Connections: Brass or 316 SS

## Environmental

Operating Temperature: 0 to 50°C (32 to 122°F)

Storage Temperature: -17 to 75°C (2 to 167°F)

Packaging: Individually packaged in lint-free bags for storage

## External Electrical Connections

<u>Connector Contact #</u>	<u>Signal Name</u>	<u>Function/ Description</u>	<u>Input/Output (Referenced to Model 415/425)</u>
1	ABZ MODE	Absolute Zero (ABZ) control > 10 Vdc= Enable ABZ < 3 Vdc= Disable ABZ	Input
2	PRESS	Pressure signal (0-5 Vdc)	Output
3	SETPT	Setpoint (user-defined and set) (0-5 Vdc)	Input
4	VCOM	Valve current common (approx. 0 Vdc)	Input
5	VTEST	Valve voltage test connection (10K series res.)	Output
6	-----	No Connection	-----
7	PWR IN	+12 to +24 Vdc power supply voltage	Input
8	SIG COM	Power supply and signal common (seperate from valve common)	Input

## Dimensional Data

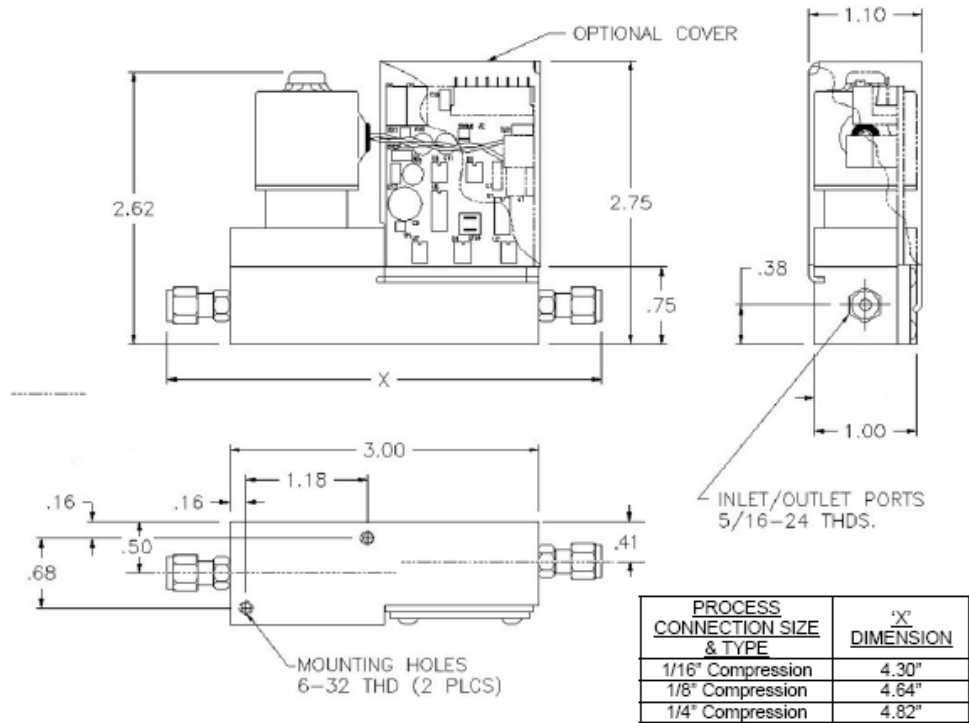

## Pressure Regulator Configurations

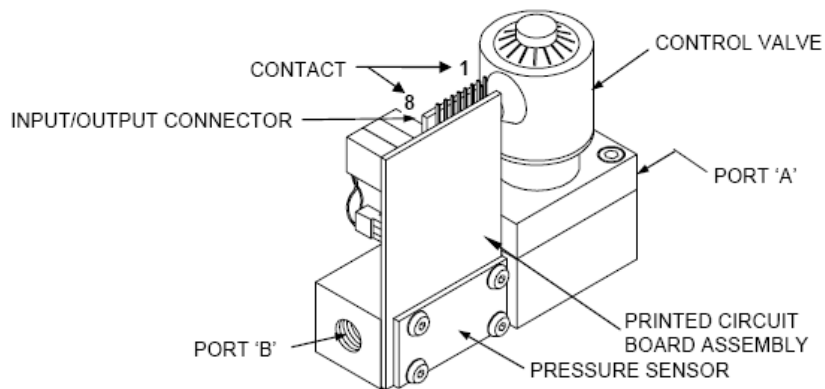

MODEL	REGULATOR TYPE	INLET PORT	OUTLET PORT
415	Forward Pressure	'A'	'B'
425	Back Pressure	'B'	'A'

# Model Number and Description

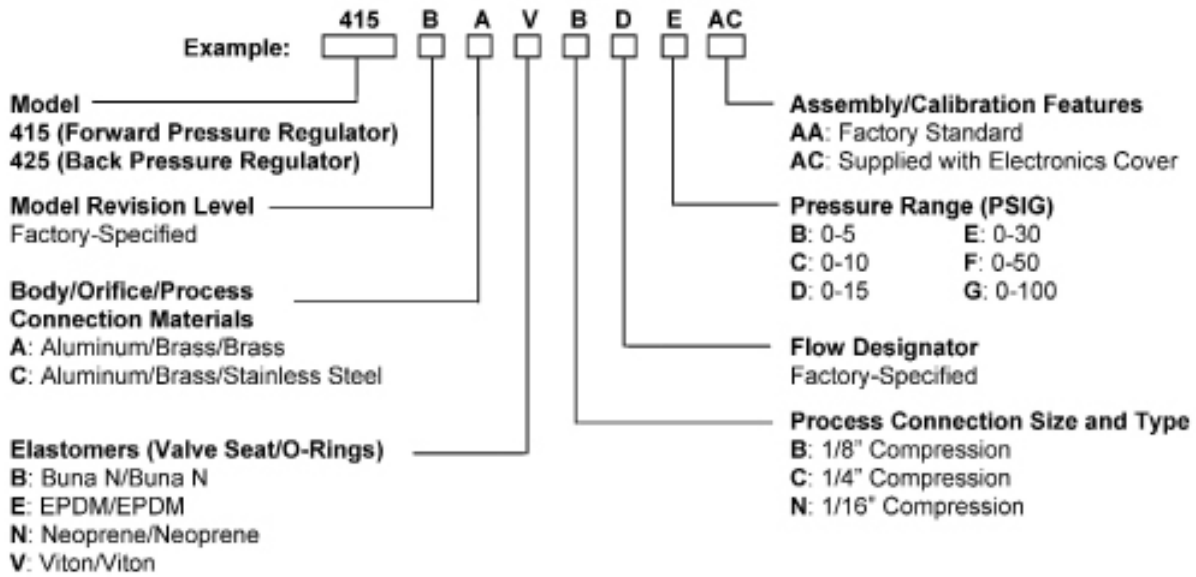

## Ordering Information

To order, please specify:

- Model Number
- Body/orifice/process connection materials
- Elastomer material
- Process connection size and type
- Flow capacity
- Gas type
- Pressure range
- Operating Temperature
- Upstream pressure
- Downstream pressure
- Process volume under pressure control

Specifications subject to change

Pyrex®- Corning Inc.  
Sandvil®- AB Sandvik Materials Technology  
Viton®- DuPont Dow Elastomers L.L.C.