

2200 Series

Mass Flow Instruments

Precise & Affordable Mass Flow Control

The Porter 2200 Series Mass Flow Instruments bring a new dimension to affordable mass flow control. Series 2200 utilizes the same proven thermal sensor assembly, control circuitry and unique laminar flow elements found in the standard Porter mass flow products. Model 2201 includes the Porter EPC proportional control valve, the same valve assembly used by many analytical instrument manufacturers for accurate gas flow control. This results in mass flow instruments that are affordable without compromising precision, control integrity or reliability.



Materials of Construction Specifications

Body	Aluminum
Valve Base (Body)	Aluminum
Orifice	Brass (Model 2201)
Valve Components (Wetted)	Stainless Steel (Model 2201)
Elastomers (O-rings and Valve Seat)	Buna N, EPDM, Neoprene or Viton®
Process Connections	Nickel-plated brass (inlet) and aluminum (outlet-integral to body)

Viton® is a registered trademark of DuPont Dow Elastomers L.L.C.

Flow Capacity	Maximum flows from 40 SCCM to 10 SLPM (based on nitrogen [N ₂] @ 70°F & 5 PSIG)
Response Time	3 to 4 seconds
Accuracy and Linearity	±2% full scale
Repeatability	Within ±0.2% full scale at any constant temperature within operating temperature range
Rangeability (Control Range)	50:1 (2%-100% full scale)
Ambient & Operating Temperature Range	-10°C to 70°C (+14°F to 158°F)
Maximum Operating Pressure	200 PSIG
Temperature Coefficient	±0.1%/°C
Pressure Coefficient	±0.1%/atmosphere typical using N ₂
Setpoint Input/Flow Signal Output	0-5 Vdc (2K ohm minimum load resistance for flow signal output)
Power Supply Requirements (current consumption <250 mAdc)	+12 (±5%) or +15 (±10%) Vdc +24 Vdc (used for 4-20 mAdc PCB)
Mounting Orientation	Attitude insensitive
Warm-up Time	10 minutes
External Electrical Connector	Nine (9)-pin D-connector
Inlet/Outlet Process Connections	1/8" female NPT

Contact Information:

Parker Hannifin Corporation
Porter Instrument Division
245 Township Line Road
Hatfield, PA 19440

phone 215 723 4000
fax 215 723 2199
Industrial@parker.com

www.parker.com



ENGINEERING YOUR SUCCESS.

Dimensions

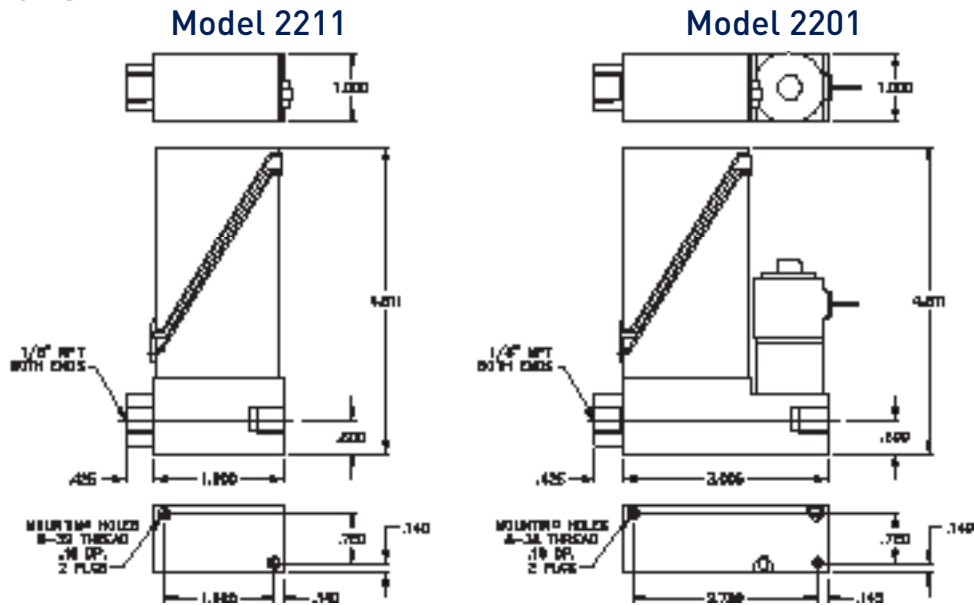

Ordering Information

To order, please specify:

- Flow capacity
- Gas type
- Operating temperature
- Inlet (supply) pressure
- Outlet pressure
- Calibration standard (i.e. 0°C, 20°C, 21.1°C or 25°C)
- Elastomer material
- Additional accessories required (e.g., interface module, inter-connecting cable assembly, etc.)

2201	A	A	A	V	C	1	AA
Basic Model Number	Model Revision	Body Orifice* / Inlet Adapter Materials		Valve Flow Designator	Valve Flow Designator	Customer Application	
2211 Mass Flowmeter 2201 Mass Flow Controller	A Factory Specified	A Aluminum/Brass/Brass (nickel-plated)		(Factory Specified, based on flow and pressures) Use X for model 2211	(Factory Specified, based on flow and pressures) Use X for model 2211	AA (Factory Specified)	
	Setpoint Signal* / Output Signal		Elastomer Material (O-Rings/Valve Seat*)		Inlet & Outlet Process Connections		
	A 0-5 Vdc / 0-5 Vdc B 0-5 Vdc / 4-20 mAdc (sinking) H 4-20 mAdc / 4-20 mAdc (sourcing) J 4-20 mAdc / 4-20 mAdc (sinking)		B Buna N/Buna N E EPDM/EPDM N Neoprene/Neoprene V Viton®/Viton®		1 1/8" Female NPT 2 1/8" Compression Fitting 3 1/4" Compression Fitting		

*Setpoint, valve orifice and seat applicable to Model 2201 only

Example: 2201AAAVC1AA

This example part number describes a 2201 model mass flow controller, factory revision A, with 0-5 Vdc setpoint and output signals, Viton® elastomers and 1/8" female NPT inlet and outlet process connections.

⚠ WARNING – USER RESPONSIBILITY

FAILURE OR IMPROPER SELECTION OR IMPROPER USE OF THE PRODUCTS DESCRIBED HEREIN OR RELATED ITEMS CAN CAUSE DEATH, PERSONAL INJURY AND PROPERTY DAMAGE.

This document and other information from Parker-Hannifin Corporation, its subsidiaries and authorized distributors provide product or system options for further investigation by users having technical expertise.

The user, through its own analysis and testing, is solely responsible for making the final selection of the system and components and assuring that all performance, endurance, maintenance, safety and warning requirements of the application are met. The user must analyze all aspects of the application, follow applicable industry standards, and follow the information concerning the product in the current product catalog and in any other materials provided from Parker or its subsidiaries or authorized distributors.

To the extent that Parker or its subsidiaries or authorized distributors provide component or system options based upon data or specifications provided by the user, the user is responsible for determining that such data and specifications are suitable and sufficient for all applications and reasonably foreseeable uses of the components or systems.